

# Vista Explodida do Produto

<b>Categoria do Produto</b>	<b>Máquina de Bebidas</b>	<b>Em caso de dúvida entre em contato com o CDP</b> <b>Códigos:</b>  <b>ATRAVÉS DE UMA SOLICITAÇÃO DE SERVIÇOS NO CRM</b>
<b>Marca do Produto</b>	<b>Brastemp</b>	
<b>Modelo</b>	<b>BPG42A</b>	

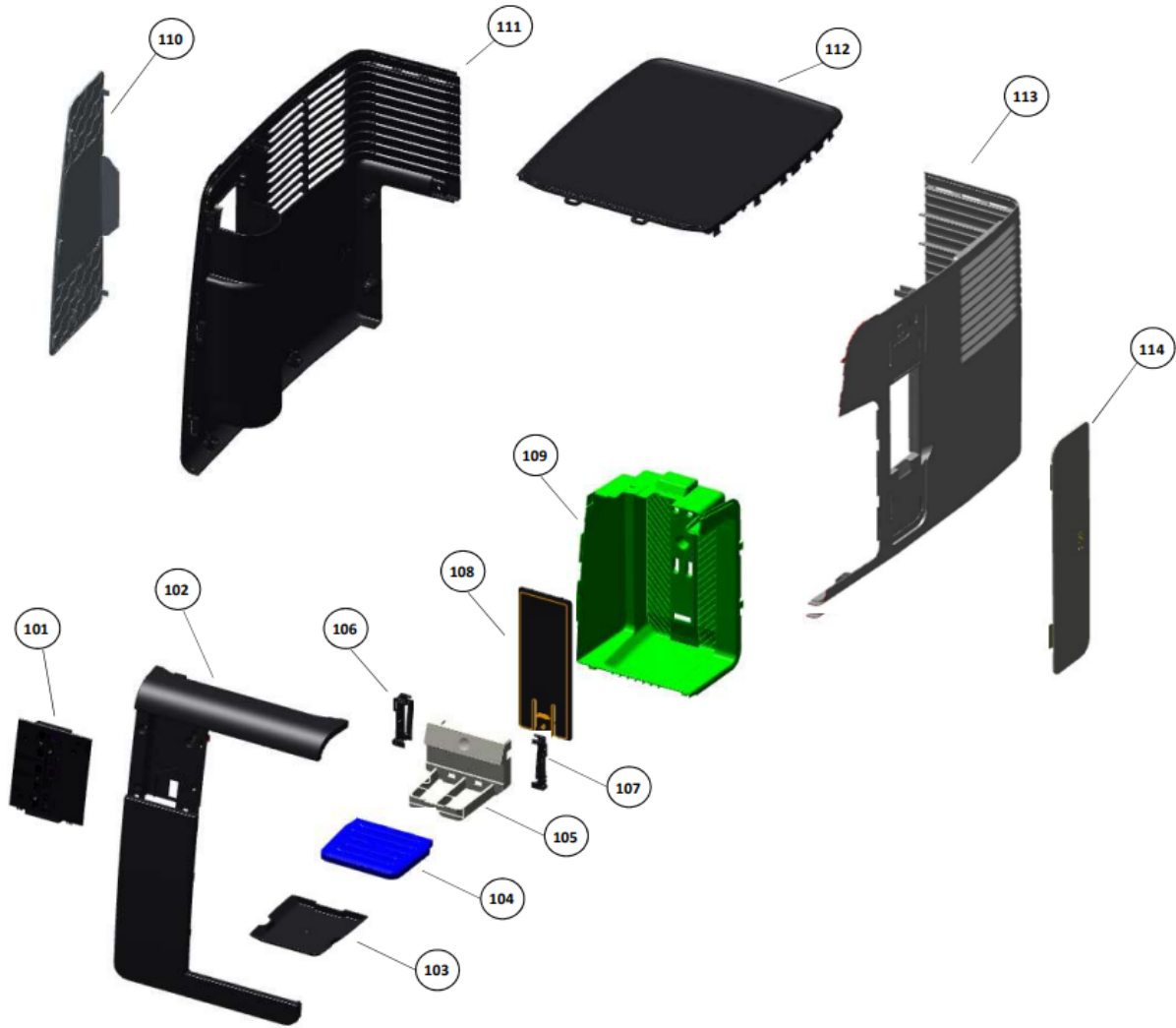

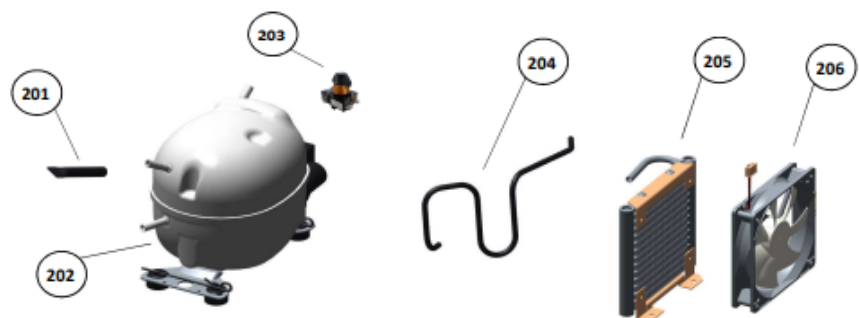



As peças indicadas com asterisco(\*) não são de reposição (via CRM) para o canal de avaliação de troca de produto, preenchendo a Categorização da solicitação de Serviço conforme abaixo:

**FASE:** Diagnóstico/Reparo.

**Categoria 1:** Produto não tem solução técnica ou peça de reposição.

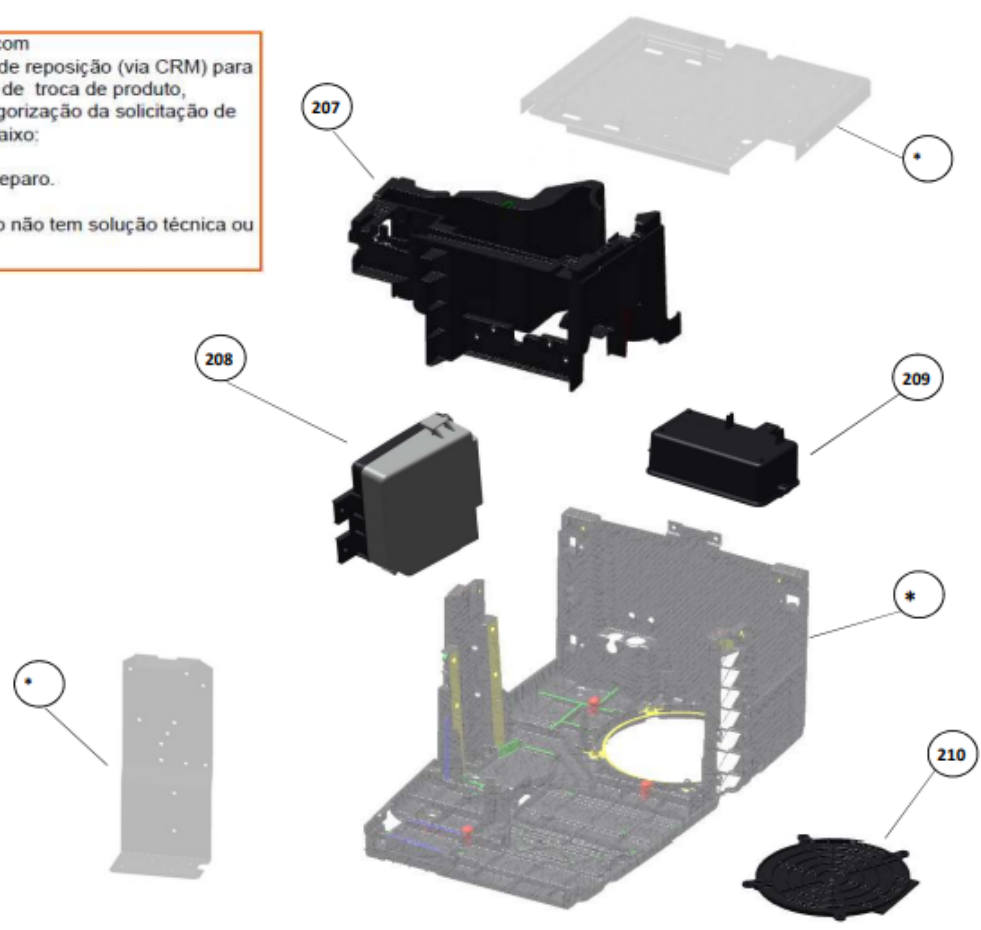

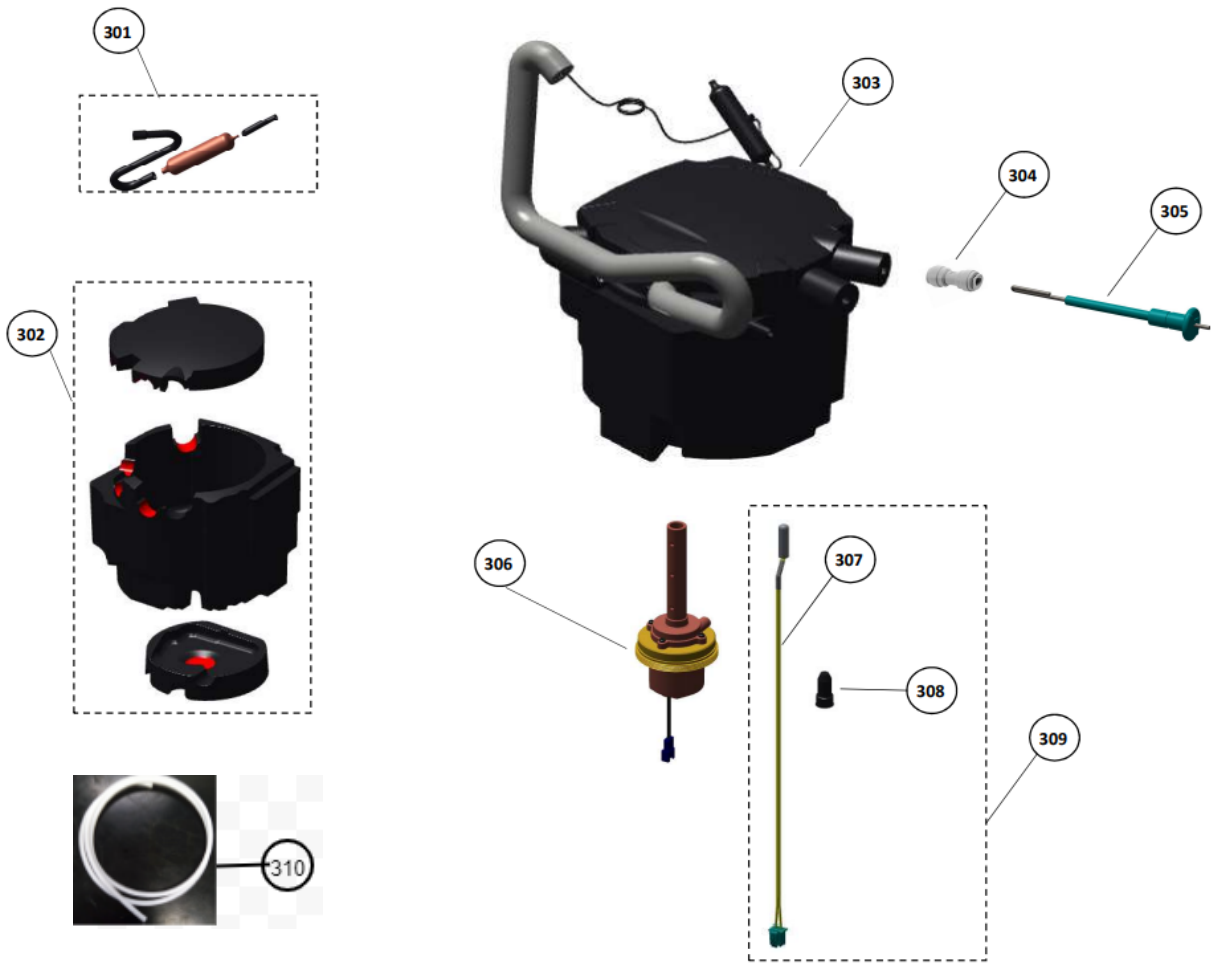

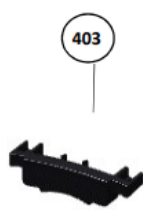
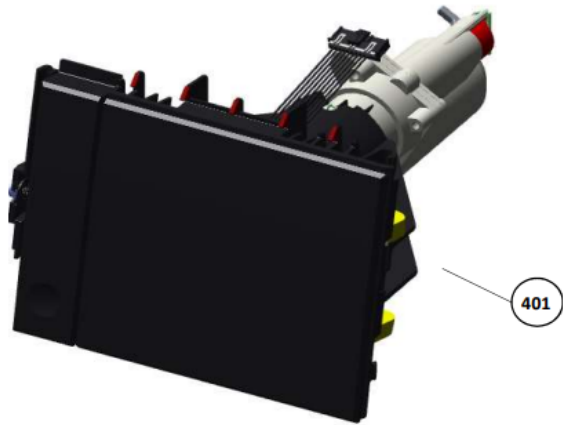



## KIT DE INSTALAÇÃO

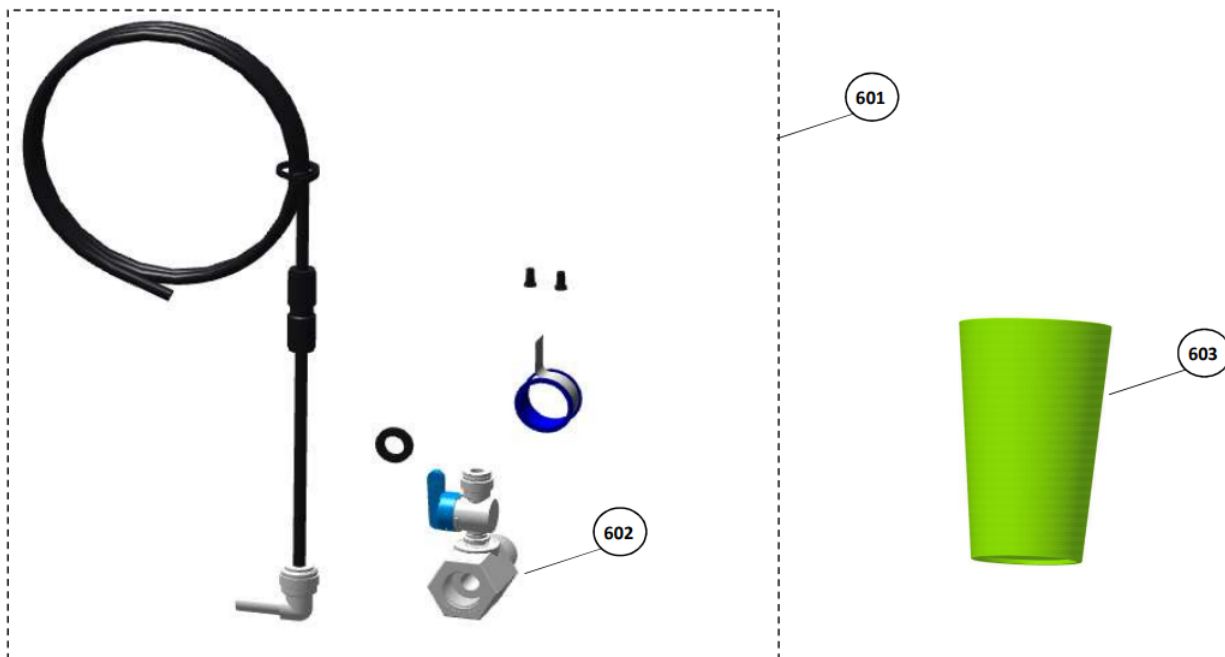

## CIRCUITO DE ENTRADA DE ÁGUA



## CIRCUITO DA BOMBA



## CIRCUITO DO FILTRO

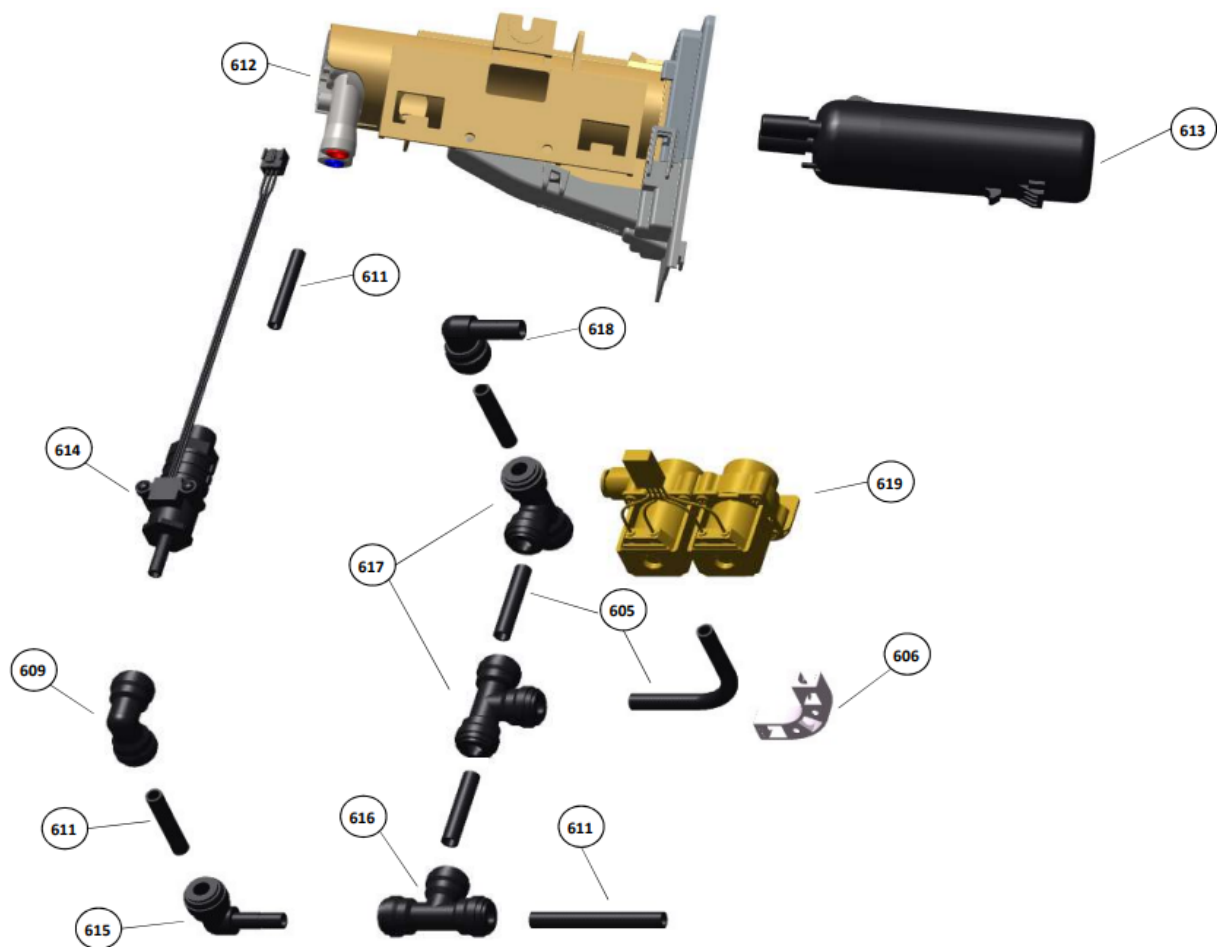



CIRCUITO DE AGUA QUENTE

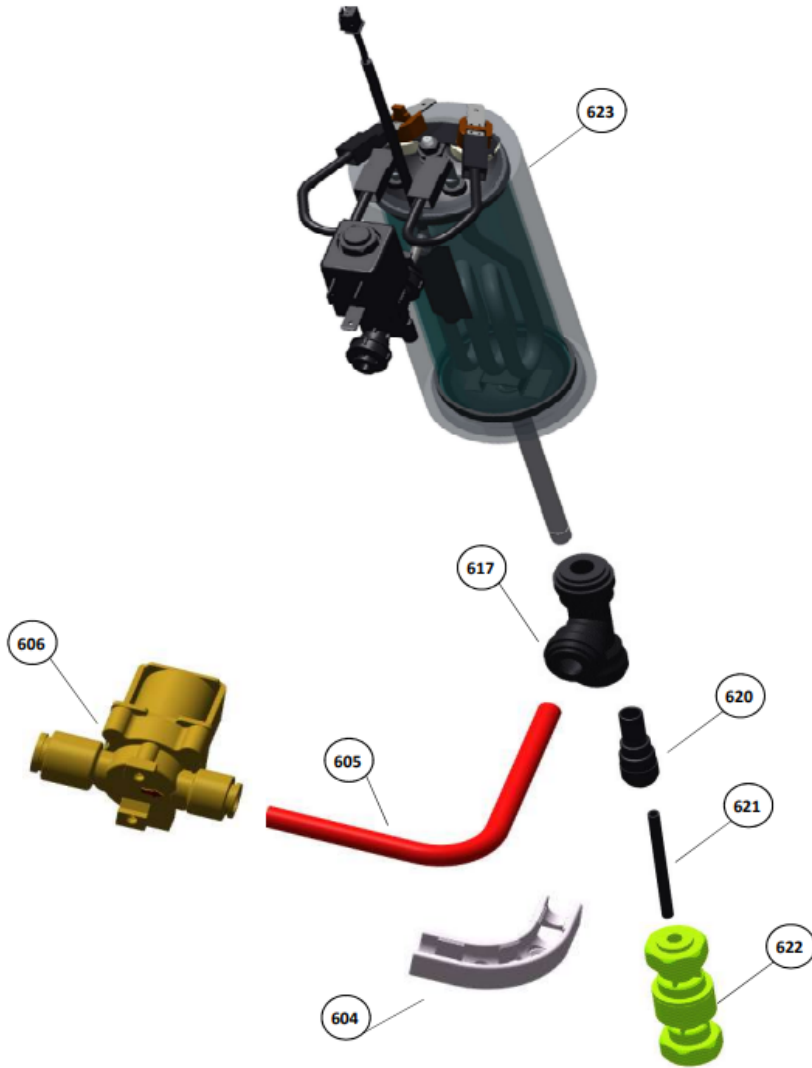

CIRCUITO DA BICA

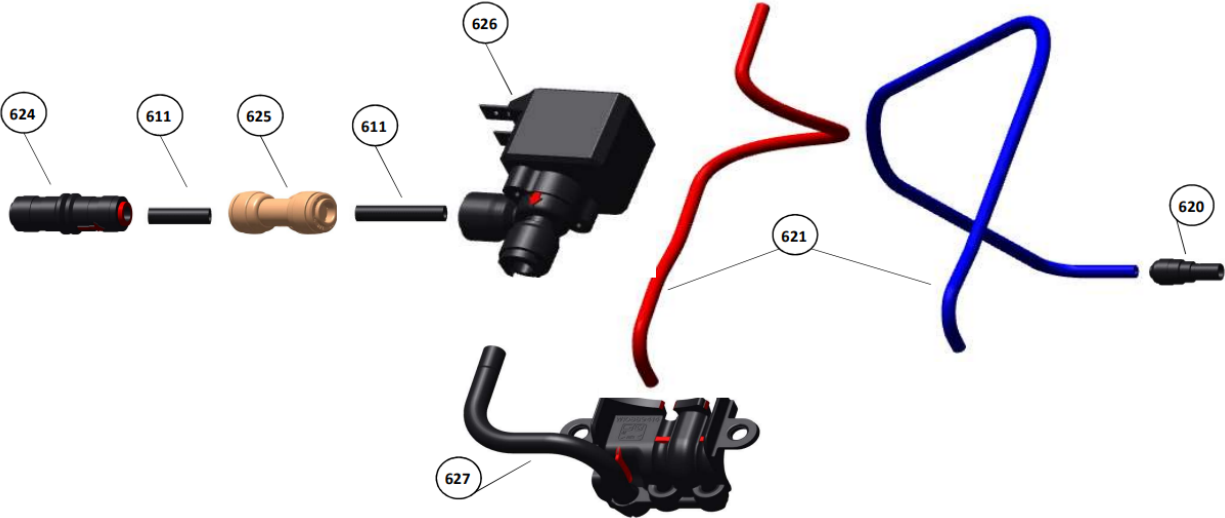

### KIT EMBAIXO DO TANQUE

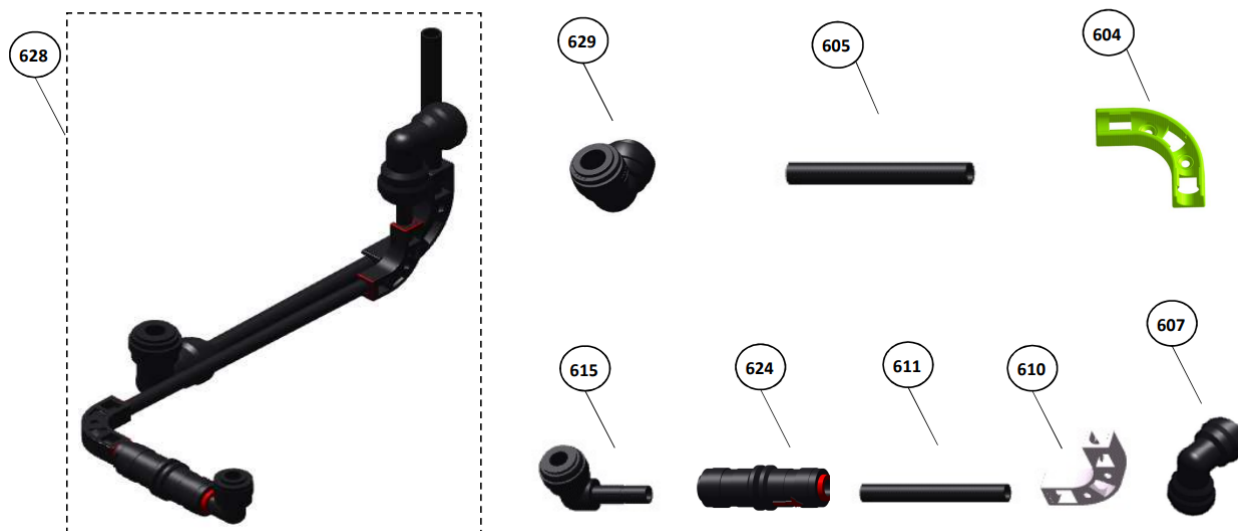

### CIRCUITO DE CO2

